



# Grass Trimmer/Brush Cutter

## *Operator's Manual*

**MODELS,**

**SRM - 2601**

**SRM - 2610**

**Serial Number 001001 & Up**

**WARNING**  **DANGER**



The muffler or catalytic muffler and surrounding cover may become extremely hot. Always keep clear of exhaust and muffler area, otherwise serious personal injury may occur.

 **WARNING** 

The engine exhaust from this product contains chemicals known to the State of California to cause cancer, birth defects or other reproductive harm.



**WARNING**  **DANGER**

Read rules for safe operation and instructions carefully. ECHO provides an Operator's Manual and a Safety Manual. Both must be read and understood for proper and safe operation. Failure to do so could result in serious injury.

## INTRODUCTION

Welcome to the ECHO family. This ECHO product was designed and manufactured to provide long life and on-the-job-dependability. Read and understand this manual and the SAFETY MANUAL you found in the same package. You will find both easy to use and full of helpful operating tips and SAFETY messages.

### WARNING DANGER

Read rules for safe operation and instructions carefully. ECHO provides an Operator's Manual and a Safety Manual. Both must be read and understood for proper and safe operation.

### THE OPERATOR'S MANUAL —

contains specifications and information for operation, starting, stopping, maintenance, storage and assembly specific to this product.

### THE SAFETY MANUAL —

explains possible hazards involved with the use of Grass Trimmers and Brush Cutters and what measures you should take to make their use safer.

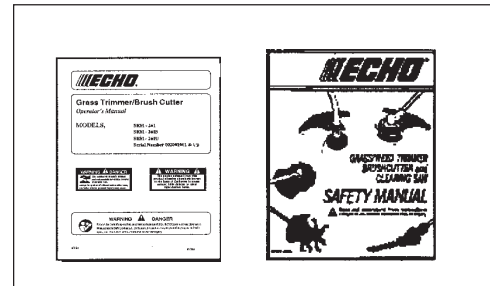

## TABLE OF CONTENTS

Introduction .....	2	- Equipment Check .....	23
- The Operator's Manual .....	2	- Determine Operation Area .....	24
- The Safety manual .....	2	Operation .....	24
Manual Safety Symbols and Important Information .....	3	- Starting Cold Engine .....	24
Safety .....	3	- Starting Warm Engine .....	25
- Decals .....	3	- Stopping Engine .....	26
- International Symbols .....	4	Maintenance .....	26
- Equipment .....	4	- Skill Levels .....	26
- Fuel .....	5	- Maintenance Intervals .....	27
- Personal Condition and Safety Equipment .....	6	- Air Filter .....	28
- Safe Operation .....	7	- Fuel Filter .....	28
- Extended Operation/Extreme Conditions .....	9	- Spark Plug .....	29
Description .....	10	- Cooling System Cleaning .....	29
- Contents .....	10	- Exhaust System .....	30
- Blade Terms and Definitions .....	10	- Carburetor Adjustment .....	31
- Emission Control .....	11	- Lubrication .....	32
Specifications .....	13	- Nylon Line Replacement .....	32
Assembly .....	14	- Sharpening Metal Blades .....	34
- Drive Shaft/Power Head .....	14	Troubleshooting .....	35
- Throttle Linkage and Ignition Leads .....	14	Storage .....	36
- Plastic Shield Installation .....	15	Servicing Information .....	40
- Nylon Head Installation .....	15	- Parts .....	40
- Front Handle Installation .....	15	- Service .....	40
- Accessory Installation .....	16	- ECHO Consumer Product Support .....	40
- Harness Clamp Installation .....	16	- Warranty Card .....	40
- Install Metal Shield .....	17	- Additional or Replacement Manuals .....	40
- U-Handle Installation .....	17	- Manual Ordering Instructions .....	40
- Muffler Bracket Installation .....	20		
Pre-Operation .....	20		
- Operation with Blades .....	20		
- Fuel .....	22		

Specifications, descriptions and illustrative material in this literature are as accurate as known at the time of publication, but are subject to change without notice. Illustrations may include optional equipment and accessories, and may not include all standard equipment.

## MANUAL SAFETY SYMBOLS AND IMPORTANT INFORMATION

Throughout this manual and on the product itself, you will find safety alerts and helpful, information messages preceded by symbols or key words. The following is an explanation of those symbols and key words and what they mean to you.

 This symbol accompanied by the words **WARNING** and **DANGER** calls attention to an act or condition that can lead to serious personal injury to operator and bystanders.

 The circle with the slash symbol means whatever is shown within the circle is prohibited.



**IMPORTANT** The enclosed message provides information necessary for the protection of the unit.

**NOTE** This enclosed message provides tips for use, care and maintenance of the unit.

## SAFETY

### DECALS

Locate these safety decals on your unit. The complete unit illustration, found in the "DESCRIPTION" section, will help you locate them. Make sure the decals are legible and that you understand and follow the instructions on them. If a decal cannot be read, a new one can be ordered from your ECHO dealer. See PARTS ORDERING instructions for specific information.

### DEBRIS SHIELD DECAL

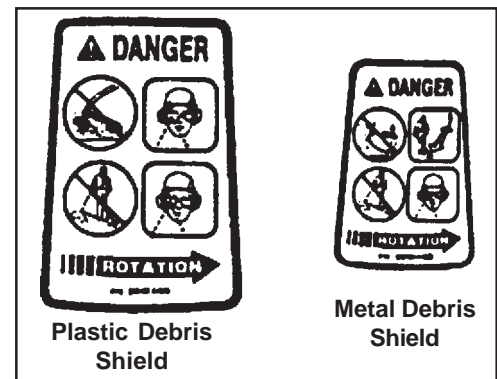



## Shaft Decal



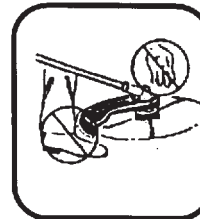





**WARNING**  **DANGER**

- This unit can be dangerous and cause serious injury if improperly used. To reduce injury risk to operator, helpers and bystanders, read and understand the Operator's and Safety manuals.
- Blindness can occur from objects that are thrown or ricocheted even with shield in place. Operators, helpers and bystanders must wear ANSI Z87.1 approved eye protection.
- Always wear hearing protection when operating unit.
- Prevent accidental contact with unit and any cutting attachment. Maintain a 15M (50 ft.) radius, **DANGER ZONE** surrounding the operator. **ONLY** the operator, dressed in proper protective clothing should be in the **DANGER ZONE**.
- Beware of **KICKOUT (blade thrust)** when using blades. Special precautions are necessary for blade operation, see your Operator's and Safety Manuals. **ONLY** install ECHO approved blades on Brush Cutters (SRM) models equipped with proper blade shield, U-handles, harness, blade collar, nut and cotter pin.
- Blade/Cutting attachment does not stop immediately after releasing throttle. Keep hands and feet clear of blade/cutting attachment unless engine is shut off and cutting attachment is not moving.
- **INSPECT BLADES BEFORE USE.**
- **DO NOT USE DAMAGED, CRACKED, BENT, DULL OR IMPROPERLY SHARPENED BLADES.**
- Do not remove shields, modify the unit or install attachments or parts not approved by ECHO. Approved attachment information and replacement Operator's and Safety Manuals are available from your ECHO dealer or by writing: **ECHO, INCORPORATED, 400 OAKWOOD RD., LAKE ZURICH, IL 60047.**



## INTERNATIONAL SYMBOLS

Symbol form/shape	Symbol description/application	Symbol form/shape	Symbol description/application
	"WARNING, SEE OPERATOR'S MANUAL"		Hot Surface
	Wear eyes, ears and head protection		Finger Severing
	Wear hand and foot protection		DO NOT allow flames or sparks near fuel.
	Safety/Alert		DO NOT smoke near fuel.
	Keep bystanders and helpers away 15 m (50 ft.).		

Symbol form/shape	Symbol description/application	Symbol form/shape	Symbol description/application
	Emergency stop		Fuel and oil mixture
	Carburetor adjustment - High speed mixture		Primer Bulb
	Carburetor adjustment - Idle speed		Ignition ON/OFF
	Carburetor adjustment - Low speed mixture		Engine choke control.

## EQUIPMENT

### **WARNING** **DANGER**

- Use only ECHO approved attachments. Serious injury may result from the use of a non approved attachment combination. Read and comply with all safety instructions listed in this manual and safety manual.
- ECHO, INC. will not be responsible for the failure of cutting devices, attachments or accessories which have not been tested and approved by ECHO.

Before operation a complete check of the unit must be performed;

- Check unit for loose/missing nuts, bolts and screws. Tighten and/or replace as needed.
- Inspect fuel lines, tank and area around carburetor for fuel leaks. DO NOT operate unit if leaks are found.
- Inspect shield for damage and ensure that the cut-off knife is securely in place. Replace if either is damaged or missing.
- Check that the cutting attachment is firmly attached and in safe operating condition.
- Check that front (loop) handle and optional shoulder/waist harness are adjusted for safe, comfortable operation. See Assembly for proper adjustment.

### **IMPORTANT**

Use of the Brush Cutter on U.S. Forest land and the states of California, Oregon and Washington requires installation of optional Muffler Bracket Kit P/N 10099057730.

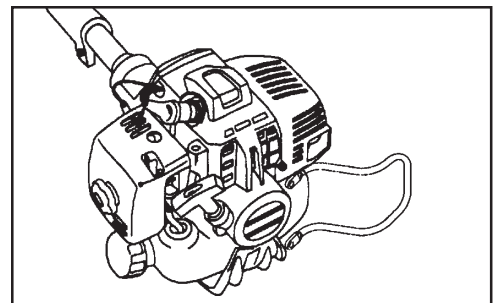

**FUEL****WARNING**  **DANGER**

Fuel is **VERY** flammable. Use extreme care when mixing, storing or handling, otherwise serious personal injury may result.

- Use an approved fuel container.
- **DO NOT** smoke near fuel.
- **DO NOT** allow flames or sparks near fuel.
- Fuel tanks/cans may be under pressure. Always loosen fuel caps slowly allowing pressure to equalize.
- **NEVER** refuel a unit when the engine is **HOT!**
- **NEVER** refuel a unit with the engine running.
- **DO NOT** fill fuel tanks indoors. **ALWAYS** fill fuel tanks outdoors over bare ground.
- Securely tighten fuel cap after refueling.
- Inspect for fuel leakage. If fuel leakage is found, do not start or operate unit until leakage is repaired.

**IMPORTANT**

Spilled fuel is a leading cause of hydrocarbon emissions. Some states may require the use of automatic fuel shut-off containers to reduce fuel spillage. Contact your ECHO dealer for ordering information.

**After Refueling;**

- Wipe any spilled fuel from the unit.
- Move at least 3 M (10 ft.) from refueling location before starting.

**After Use;**

- **DO NOT** store a unit with fuel in its tank. Leaks can occur. Return unused fuel to an approved fuel storage container.

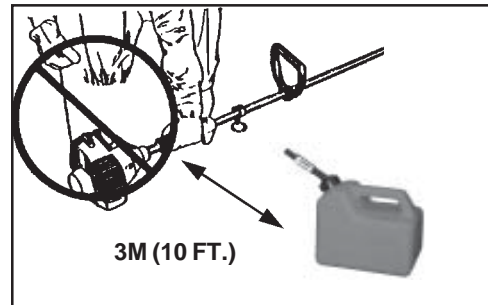
**PERSONAL CONDITION AND SAFETY EQUIPMENT****WARNING**  **DANGER**

Trimmer/Brush Cutter users risk injury to themselves and others if the trimmer/brush cutter is used improperly and or safety precautions are not followed. Proper clothing and safety gear must be worn when operating a trimmer.

## **Physical Condition --**

Your judgment and physical dexterity may not be good:

- if you are tired or sick,
- if you are taking medication,
- if you have taken alcohol or drugs.

Operate unit only if you are physically and mentally well.



## **Eye Protection --**

Wear eye protection that meets ANSI Z87.1 or CE requirements whenever you operate the trimmer.



## **Hand Protection --**

Wear no-slip, heavy duty work gloves to improve your grip on the Trimmer/Brush Cutter handles. Gloves also reduce the transmission of machine vibration to your hands.

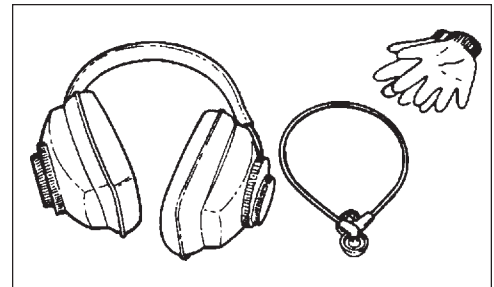

## **Hearing Protection --**

ECHO recommends wearing hearing protection whenever unit is used.



## **Proper Clothing --**

Wear snug fitting, durable clothing;

- Pants should have long legs, shirts with long sleeves.
- **DO NOT WEAR SHORTS,**
- **DO NOT WEAR TIES, SCARVES, JEWELRY.**

Wear sturdy work shoes with non-skid soles;

- **DO NOT WEAR OPEN TOED SHOES,**
- **DO NOT OPERATE UNIT BAREFOOTED.**

## **Hot Humid Weather --**

Heavy protective clothing can increase operator fatigue which may lead to heat stroke. Schedule heavy work for early morning or late afternoon hours when temperatures are cooler.

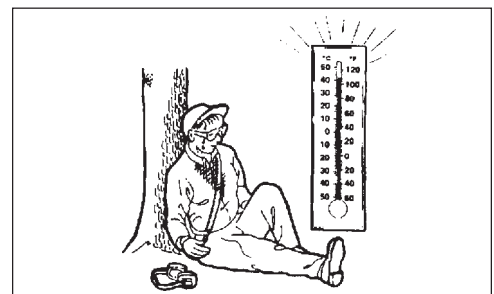

## SAFE OPERATION

### *Determine Operation Area*

- Provide all operators of this equipment with the Operator's Manual and instructions for safe operation.
- Review the area to be trimmed. Look for hazards that could contribute to unsafe conditions.
- Spectators and fellow workers must be warned, and children and animals prevented from coming nearer than 15M (50 ft.) while the trimmer is in use.

### *Operation*

#### Use Proper Clothing & Equipment

- Before starting the unit, equip yourself and any other person working within the 15M (50 ft.) Safety Zone with the required Protective Equipment and clothing.

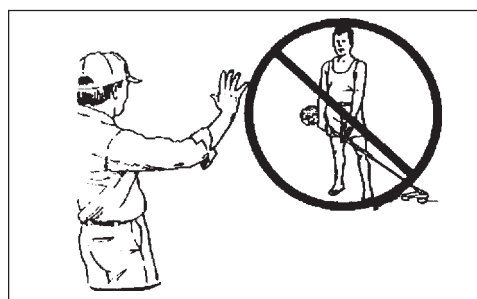
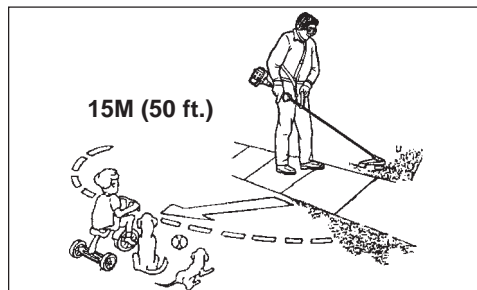

### **WARNING** **DANGER**

Do not operate this product indoors or in inadequately ventilated areas. Engine exhaust contains poisonous emissions and can cause serious injury or death.

#### Avoid Hot Surfaces

- During operation, the complete unit, especially the drive shaft housing and the bearing housing may become very hot, too hot to touch. Avoid contact during and immediately after operation.

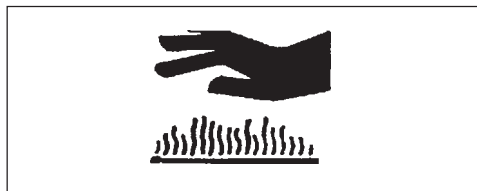

#### Keep A Firm Grip

- Hold the front and rear handles with both hands with thumbs and fingers encircling the handles

#### Keep A Solid Stance

- Maintain footing and balance at all times. Do not stand on slippery, uneven or unstable surfaces. Do not work in odd positions or on ladders. Do not over reach.





## EXTENDED OPERATION/EXTREME CONDITIONS

### *Vibration and Cold*

It is believed that a condition called Raynaud's Phenomenon, which affects the fingers of certain individuals may be brought about by exposure to vibration and cold. Exposure to vibration and cold may cause tingling and burning sensations followed by loss of color and numbness in the fingers. The following precautions are strongly recommended because the minimum exposure which might trigger the ailment is unknown.

- Keep your body warm, especially the head, neck, feet, ankles, hands and wrists.
- Maintain good blood circulation by performing vigorous arm exercises during frequent work breaks and also by not smoking.
- Limit the hours of operation. Try to fill each day with jobs where operating the trimmer or other hand-held power equipment is not required.
- If you experience discomfort, redness and swelling of the fingers followed by whitening and loss of feeling, consult your physician before further exposing yourself to cold and vibration.

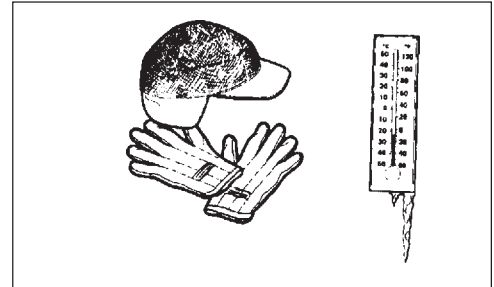

### *Repetitive Stress Injuries*

It is believed that overusing the muscles and tendons of the fingers, hands, arms and shoulders may cause soreness, swelling, numbness, weakness and extreme pain in those areas. Certain repetitive hand activities may put you at a high risk for developing a Repetitive Stress Injury (RSI). An extreme RSI condition is Carpal Tunnel Syndrome (CTS), which could occur when your wrist swells and squeezes a vital nerve that runs through the area. Some believe that prolonged exposure to vibration may contribute to CTS. CTS can cause severe pain for months or even years. To reduce the risk of RSI/CTS, do the following:

- Avoid using your wrist in a bent, extended or twisted position. Instead try to maintain a straight wrist position. Also, when grasping, use your whole hand, not just the thumb and index finger.
- Take periodic breaks to minimize repetition and rest your hands.
- Reduce the speed and force with which you do the repetitive movement.
- Do exercises to strengthen the hand and arm muscles.
- Immediately stop using all power equipment and consult a doctor if you feel tingling, numbness or pain in the fingers, hands, wrists or arms. The sooner RSI/CTS is diagnosed, the more likely permanent nerve and muscle damage can be prevented.

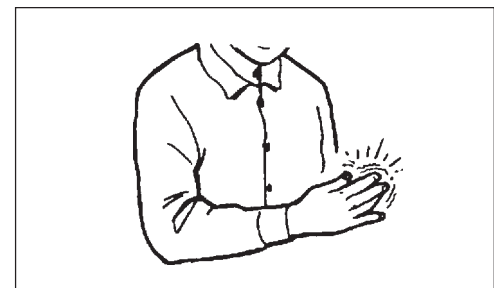
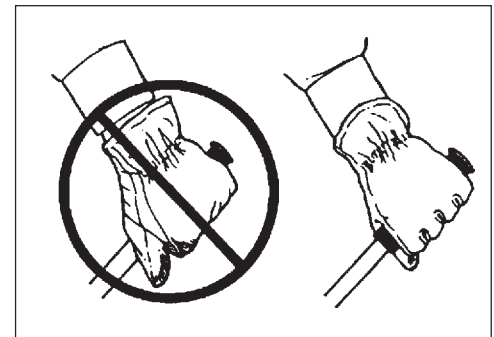

## DESCRIPTION

The ECHO product you purchased has been factory pre-assembled for your convenience. Due to packaging restrictions, shield installation and other assembly may be necessary.

After opening the carton, check for damage. Immediately notify your retailer or ECHO Dealer of damaged or missing parts. Use the contents list to check for missing parts.

## CONTENTS

<i>Contents List</i>		
Items	MODELS	
	2601 1E	2610 1E
1 - Power Head	√	√
1 - Drive Shaft Assembly	√	√
1 - Plastic Bag (co-pack)	√	√
- 1, Operator's Manual	√	√
- 1, Safety Manual	√	√
- 1, Warranty Registration Card	√	√
- 1, Limited Warranty Statement	√	√
- 1, Plastic shield	√	√
- 1, Tool Bag	√	√
--1, T-wrench	√	√
--1, locking tool	√	√
--1, 8 x 10mm wrench	√	√
- 1, Nylon Trimmer Head	√	√
- 1, Safety Glasses	√	√
- 1, 2-Stroke Oil Sample, 2.6 oz.	√	√
- 1, Front Handle (L.H.)	√	√
- 1, Plastic Bag	√	√
--1, shield plate	√	√
--3, 5mm x 15mm screws (shield mtg.)	√	√
--1, 4mm Hexagon Wrench	√	√
- 1, Plastic Bag	√	√
-- 3, 5mm x 15mm screws (shield mount)		√
-- 2, 5mm x 8mm screws (bracket to shield)		√
-- 4, 5mm nuts		√
-- 4, 5mm lockwashers		√
--1, metal shield		√
--1, bracket		√
-1, plastic bag		√
-1, 8mm x 55mm bolt		√
-2, cable clips		√

## BLADE TERMS AND DEFINITIONS --

### **Blade Convertible**

Models (SRM-2601) can be converted to utilize blades. Plastic/nylon blades require a, "Blade Conversion Kit" P/N 99944200415, which includes a shoulder harness, and steel shield with necessary attaching hardware. Steel/metal blades require Combination "U-Handle/Blade Conversion Kit" P/N 99944200521 which includes Blade Conversion Kit Parts, U-Handle, Throttle Cable and Stop Switch.

### **Dedicated Blade Capable**

Model (SRM-2610) includes the "U-Handle/Blade Conversion Kit".

## EMISSION CONTROL --

The emission control system for this engine is EM (Engine Modification).

**Emission Control Label** located on Engine  
(EXAMPLE ONLY, information on label varies by FAMILY).

IMPORTANT ENGINE INFORMATION

ENGINE FAMILY : VEH025UB24RA  
 DISPLACEMENT : 25.4cc  
 THIS ENGINE MEETS U.S. EPA PHI AND 1995 - 1999  
 CALIFORNIA EMISSION REGULATIONS FOR ULGE  
 ENGINES. REFER TO OWNER'S MANUAL FOR  
 MAINTENANCE SPECIFICATIONS AND ADJUSTMENTS.

**ECHO CORP.**

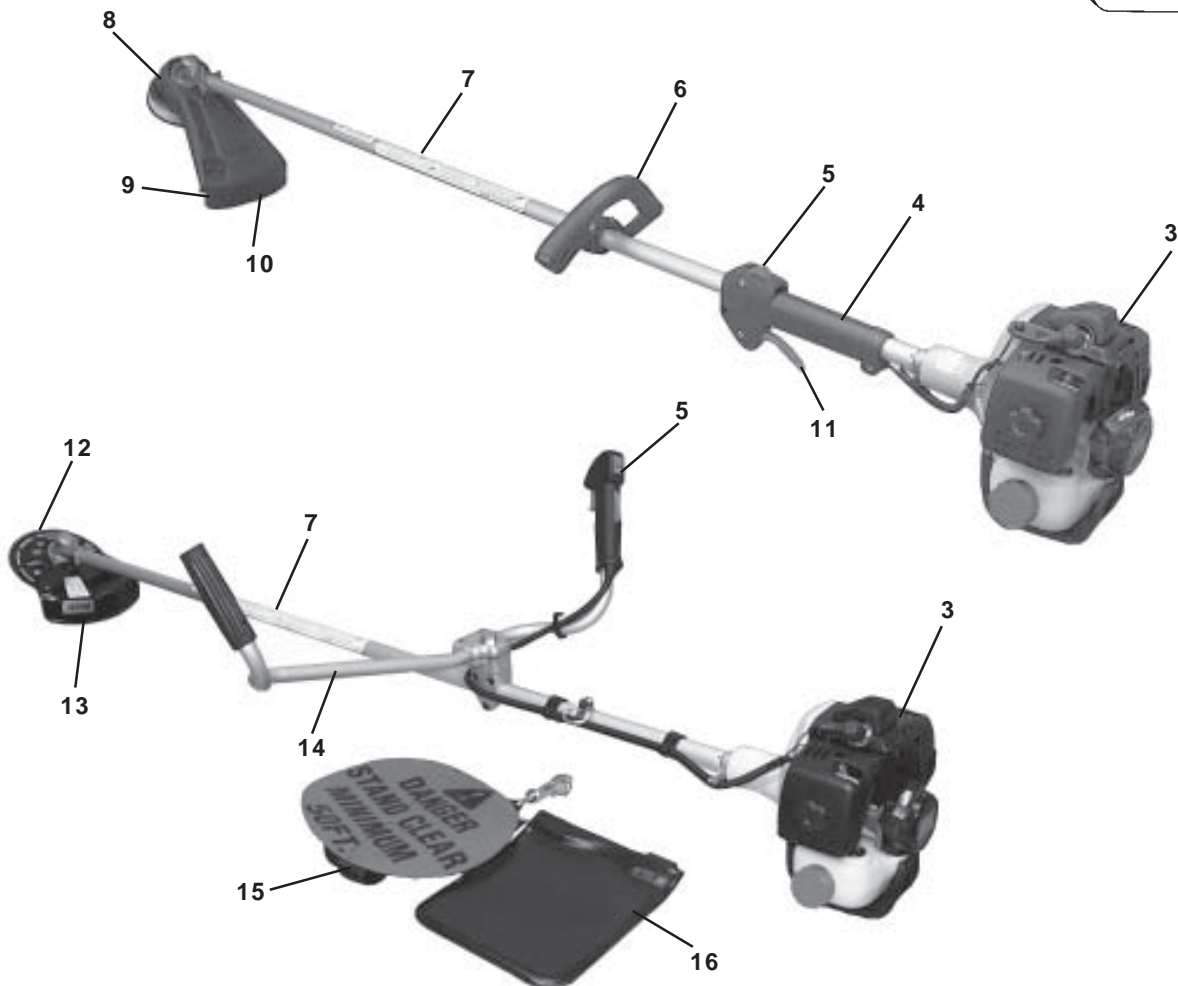
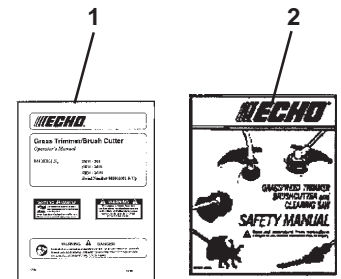
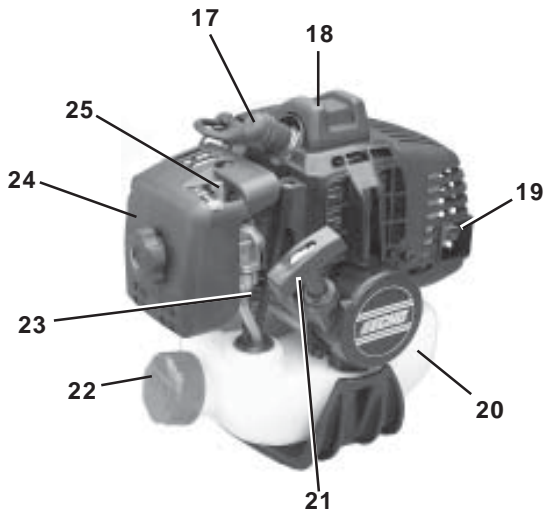
1. **OPERATOR'S MANUAL** - Included in plastic bag (co-pack). Read before operation and keep in a safe place for future reference, i.e., operation, maintenance, storage and specifications.
2. **SAFETY MANUAL** - Included in plastic bag (co-pack). Read before operation and keep in a safe place for future reference to learn proper, safe operating techniques.
3. **POWER HEAD** - Includes the Engine, Clutch, Fuel System, Ignition System and Recoil Starter.
4. **GRIP** - Rear (right hand) handle.
5. **STOP SWITCH** - "SLIDE SWITCH" mounted on top of the Throttle Trigger Housing. Move switch FORWARD to RUN, BACK to STOP.
6. **FRONT HANDLE** - The Front (loop) handle is loosely assembled to the Drive Shaft assembly and must be positioned for proper cutting attitude and operator comfort.
7. **DRIVE SHAFT ASSEMBLY** - Includes the Rear (right hand) Handle assembly, Gear Housing assembly, Front (loop, left hand) Handle assembly, steel drive shaft and Safety Decal.
8. **NYLON CUTTER HEAD** - Contains replaceable nylon trimming line that advances when the trimmer head is tapped against the ground while the head is turning at normal operating speed.
9. **CUT-OFF KNIFE** - Automatically trims line to the correct length: 5" after head is tapped on the ground. If trimmer is operated without a cut-off knife the line will become too long, the engine will overheat and engine damage may occur.
10. **PLASTIC DEBRIS SHIELD ASSEMBLY** - Included in plastic bag (co-pack). **MUST** be installed on unit before use, see Assembly Instructions. Shield assembly includes the Cut-Off Knife and Safety Decal. Mounts on the Gear Housing Assembly just above the cutting attachment. Helps protect the operator by deflecting debris produced during the trimming operation. This shield must be replaced with the steel shield for blade use.
11. **THROTTLE TRIGGER** - Spring loaded to return to idle when released. During acceleration, press trigger gradually for best operating technique.
12. **BLADE** - Circular blade for grass, weed or brush cutting applications. Harness, metal shield & U-handles required for blade operation.
13. **METAL BLADE SHIELD** - Required when unit is equipped with blades. Do not operate unit without shield.
14. **U-HANDLE** - Required for metal blade operation.
15. **SHOULDER HARNESS** - An adjustable strap that suspends the unit from the operator. Using the strap reduces operator fatigue.
16. **HIP PAD** - Used to protect hip/leg and clothing when using U-handle equipped unit.
17. **SPARK PLUG** - Provides spark to ignite fuel mixture.
18. **ARM REST** - Provides arm rest during operation and protects arm from the hot engine.
19. **MUFFLER/SPARK ARRESTER** - The muffler controls the exhaust noise while the spark arrester prevents hot, glowing particles of carbon from leaving the muffler where they could possibly start a fire.
20. **FUEL TANK** - Contains fuel and fuel filter.
21. **RECOIL STARTER HANDLE** - Pull handle slowly until starter engages, then quickly and firmly. When engine starts, return handle slowly. **DO NOT** let handle snap back or damage to unit will occur.
22. **FUEL TANK CAP** - Covers and seals fuel tank opening.
23. **PRIMER BULB** - Pumping primer bulb before starting engine draws fresh fuel from the fuel tank priming the carburetor for starting. Pump the bulb 10 times until fuel is visible in clear fuel return line.
24. **AIR CLEANER** - Contains replaceable filter element.
25. **CHOKE** - The choke control is located on the top of the air filter case. Move **choke control** up to close the choke for cold starting. Push knob down for the "RUN" position.
26. **SAFETY VIDEO** - (Not included with unit) P/N 99922202540 English version only is available at a cost of \$5.00 from ECHO, INC. or any authorized ECHO dealer. The video overviews safety precautions and proper operating techniques and is supplemental to the Safety Manual. Read and understand the Safety Manual for complete information on safe operation.

## SPECIFICATIONS

MODEL	SRM-2601 1E	SRM-2610 1E
Length	1800 mm (70.9 in.)	1800 mm (70.9 in.)
Width	315 mm (12.4 in.)	600 mm (23.6 in.)
Height	285 mm (11.0 in.)	285 mm (11.0 in.)
Weight (dry) w/Cutter Head	5.5 kg (11.5 lb.)	5.8 kg (12.2 lb.)
Engine Type	Air cooled, two-stroke, single cylinder gasoline engine	
Bore	34.0 mm (1.34 in.)	
Stroke	28.0 mm (1.10 in.)	
Displacement	25.4 cc (1.55 cu. in.)	
Exhaust	Spark Arrestor Muffler	
Carburetor	Walbro diaphragm model WYJ w/purge pump	
Ignition System	Flywheel magneto, transistor control ignition type	
Spark Plug	NGK BPM-7Y (Gap 0.65 mm (0.026 in.))	
Fuel	Mixed (Gasoline and Two-stroke Oil)	
Fuel/Oil Ratio	50:1 ECHO High Performance, two-stroke air cooled engine oil	
Gasoline	89 Octane unleaded. DO NOT use fuel containing methyl alcohol, more than 10% ethyl alcohol or 15% MTBE.	
Oil	50:1 ECHO High Performance, two-stroke air cooled engine oil	
Fuel Tank Capacity	0.69 lit. (23.4 US fl. oz.)	
Starter System	Automatic Rewind Starter	
Clutch	Centrifugal Type	
Vibration Isolated System	Rubber cushion on engine mount (heavy duty). Rubber anti-vibration grip on front handle.	
Operating Rod	25.0 mm aluminum Tube	
Drive Shaft	7.0 mm Spline steel shaft	
Gear Case Ratio	1:1.4 Reduction	
Rotating Direction	Counter Clockwise; viewed from top	
Cutter Head	Nylon line head (2-line) with .095 Crossfire™ Line capacity 13m (40 ft.) Optional: U-Handle Kit, 8 cutter blade (8 in.); 22-tooth blade (8 in.); Circular saw (8 in.) MAXI-CUT, TRI-CUT, RSAR-2501, RSAC-200 UNIVERSAL HEADS	
Handle	Front - D-Loop type with rubber anti-vibration grip. Rear - Rubber grip.	U-Handle
Shoulder Harness	Optional	Standard
Idle Speed	2800 - 3200 RPM	
Wide Open Throttle Speed (W.O.T.) with Nylon Line Head	8800 - 9600 RPM	
Wide Open Throttle Speed (W.O.T.) with Blade	9500 - 11000 RPM	

## ASSEMBLY

### DRIVE SHAFT/POWER HEAD

*Tools Required:* 4mm Hex Wrench

*Parts Required:* Power head, Drive shaft Assembly

1. Loosen, the bolt (A) at engine drive shaft clamp.
2. Carefully fit drive shaft assembly to engine making sure that inner drive shaft engages into clutch mount.

#### NOTE

Lower gear housing and head assembly must be in line with the engine.

3. Turn drive shaft housing so that center line of housing is midway between the two arrows on shaft.
4. Tighten bolt (A).

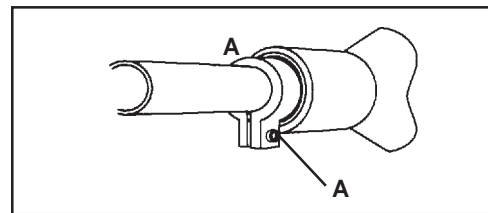
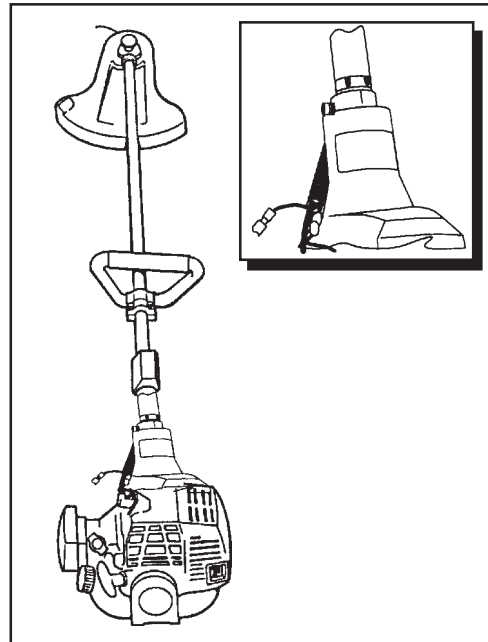
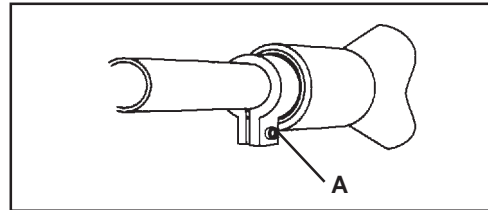

### THROTTLE LINKAGE AND IGNITION LEADS

1. Close choke and remove air filter cover.
2. Connect ignition stop leads (A) and (B).
3. Place throttle linkage (E) through adjustment fixture (F) and install wire end into large carburetor throttle swivel hole (D). Check throttle for freedom of movement and that wide open throttle / low idle extremes are adjusted properly. The throttle linkage must be adjusted by moving the adjustment fixture (F). Consult with your Echo Dealer for correct adjustment procedure.
4. Install air filter cover.

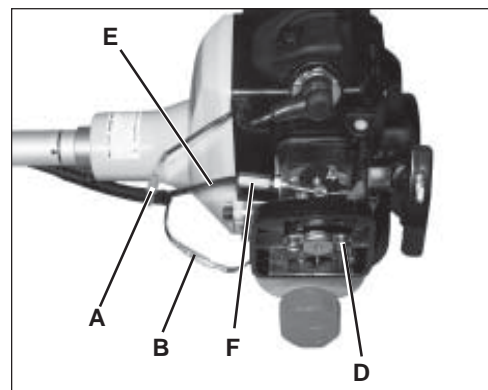

## PLASTIC SHIELD INSTALLATION

(for Nylon Line Operation)

*Tools Required:* Screwdriver.

*Parts Required:* Plastic Shield, Shield Plate, three (3) 5mm x 15mm screws.

### NOTE

The plastic shield is for use with the Nylon Line Head only.  
Install Metal Shield when using plastic or metal blades.

1. Remove plastic threaded shaft sleeve and adapter plate from PTO shaft.
2. Snap the shield on the bottom of the bearing housing flange.
3. Place shield plate on shield, align holes. Install three (3) screws from bottom through plate and shield into gearcase.
4. Reassemble adapter plate onto threaded shafts



## NYLON LINE HEAD INSTALLATION

*Tools Required:* Head Locking Tool,

*Parts Required:* Nylon Line Head.

1. Remove plastic sleeve from gear housing shaft.
2. Be sure plate (A) remains on PTO shaft.
3. Align locking hole in upper plate with notch in edge of gear housing and insert head locking tool (B).
4. Thread line head onto shaft by turning it counter clockwise until head is tight against upper plate.

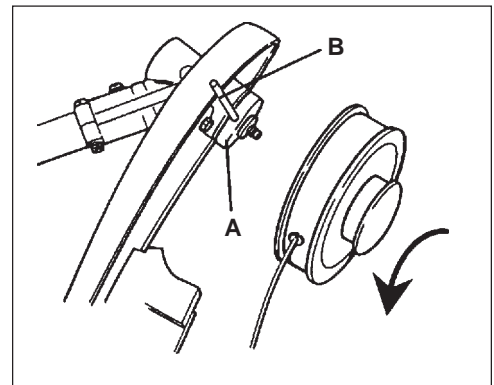

## FRONT HANDLE INSTALLATION

*Tools Required:* Screwdriver.

*Parts Required:* Front Handle Assembly

1. Position front handle for comfortable operation and secure screws.





**NOTE**

For SRM-2610 handle assembly refer to "U-Handle Installation page 18 instructions 1, 10, 12 - 16.



## ACCESSORY INSTALLATION

Blade Conversion Kit P/N 99944200415, U-Handle / Blade Conversion Kit P/N 99944200521, Muffler Bracket Kit P/N 10099057730.

**NOTE**

Refer to Operation with Blades page 20 for correct Accessory / Blade equipment requirements.

## WARNING DANGER

You must install a U-Handle/Blade Conversion Kit before operating this unit using metal blades, otherwise serious injury may result.

## HARNES CLAMP INSTALLATION

**NOTE**

SRM-2601 requires installation of Harness Clamp included in the Blade Conversion Kit or U-Handle / Blade Conversion Kit. If your unit does not have a clamp, follow these directions.

*Tools Required:* Screwdriver, 8mm x 10mm Open End Wrench.

1. Remove shield and gear housing as an assembly.
  - a. Loosen two (2) screws (A) that clamp the gear housing to the drive shaft housing.
  - b. Remove locating screw (B) found at the top of the gear housing. Pull shield and gear housing assembly from the drive shaft assembly.

**IMPORTANT**

Prevent steel drive shaft from sliding from drive shaft housing. If shaft does slide free, clean dirt from shaft and re-assemble.

2. Remove front handle.
  - a. Remove four (4) screws and nuts and handle support from handle.
  - b. Remove handle.
3. Install clamp.

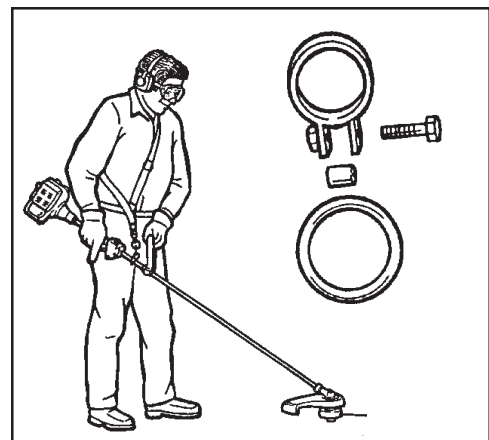
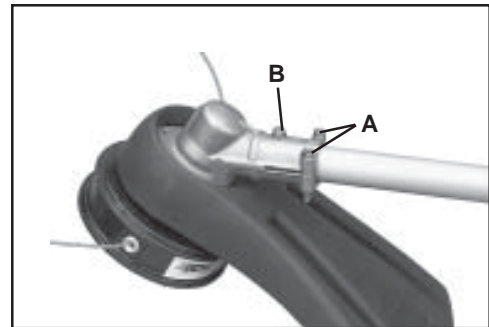



4. Install front handle, gear housing and shield.
5. Balance unit.
  - a. Put on harness and attach unit to harness.
  - b. Slide harness clamp (J) up or down until unit balances with cutting attachment approximately 2" - 3" from the ground.
  - c. Tighten harness clamp screw.



## INSTALL METAL SHIELD

*Tools Required:* 8mm x 10mm Open End Wrench, Screwdriver.

*Parts Required:* Metal Shield, Bracket, 3 - 5 mm x 15 mm screws w/captivated flat and lockwasher (metal shield to gear housing), 2 - 5 mm x 8 mm screws, 4 - 5 mm nuts, 4 - 5 mm lockwashers (bracket to shield and bracket to gear housing).

1. If necessary, remove nylon line head and plastic shield.
2. Loosely attach bracket (A) to shield (B) and attach to bottom of gear housing (C) with screws and nuts provided. Tighten all attaching hardware.

### **Install Blade**

*Tools Required:* Locking Tool, srench.

*Parts Required:* 1 - Upper Fixing Plate, 1 - Lower Fixing Plate, 1 - 10 mm L.H. Nut, 1 - 2x22 mm Split Pin.

3. Install upper plate (D) on splined shaft. 20 mm center hole blade requires use of Upper Plate (D) with 20 mm pilot. 25 mm center hole blade requires use of upper plate (D) with 25 mm pilot. Upper plate with 37 mm pilot of the SRM-2601 should be retained for use with nylon line head.
4. Place Blade (E) over upper plate pilot, install the Lower Plate (F) and 10mm LH nut (G). Tri-Cut Blade (H) is installed with Glide Cup (J).
5. Insert Locking Tool (K) through hole in upper plate and notch in gear housing to prevent splined shaft from turning. Tighten nut and secure with Split Pin (L).

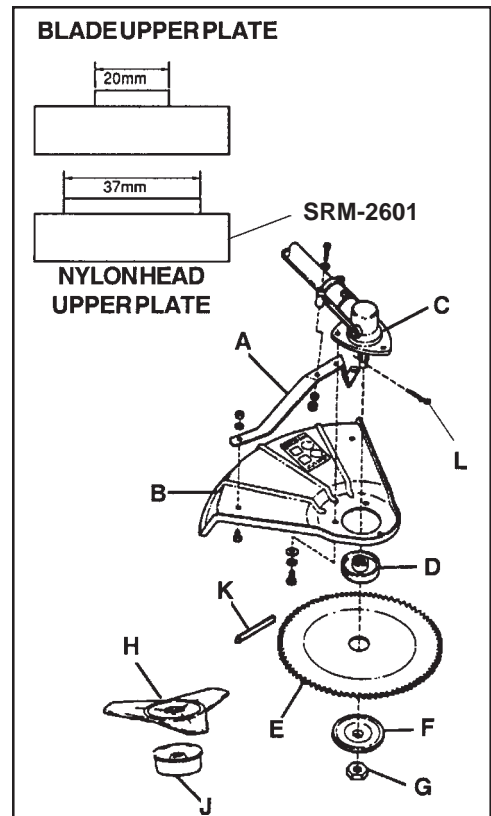

## U-HANDLE INSTALLATION

*Tools Required:* 8mm x 10mm Open End Wrench, Screwdriver, 3mm and 4mm Hex Wrench, Pliers

*Parts Required:* U-Handle/Blade Conversion Kit P/N 99944200521.

### NOTE

For model SRM-2610 use Steps 1, 10, 12 - 16.

1. Close choke and remove air filter cover.
2. Disconnect ignition stop leads (A) and (B).
3. Remove inner throttle linkage from carburetor swivel (D).
4. Remove throttle linkage (E) from throttle linkage fixture (F).
5. Loosen bolt (G) and pull drive shaft assembly from clutch case.
6. Loosen two (2) rear handle screws (H) and pull rear handle (I) from the drive shaft assembly.
7. Loosen four (4) screws and remove front handle (J).
8. Position lower U-Handle bracket (K) 400mm (15-3/4 in.) from engine end of drive shaft. Secure with three (3) 5mm x 30mm bolts.
9. Position harness hook 220mm (8-5/8 in.) from engine end of drive shaft assembly. **DO NOT** tighten at this time.
10. Install upper U-Handle and bracket on lower bracket and secure with one (1) 8mm x 55mm bolt (L) and large circular washer.
11. Install power head and align gear box, power head and U-Handles. Tighten all screws.

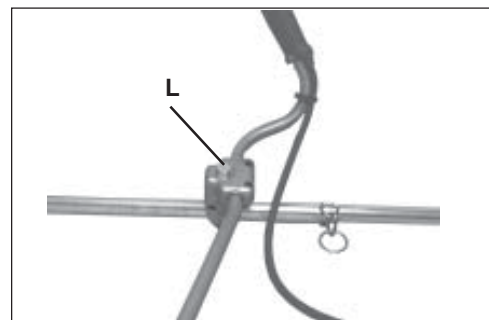
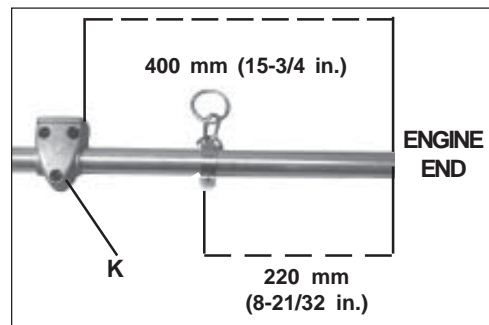
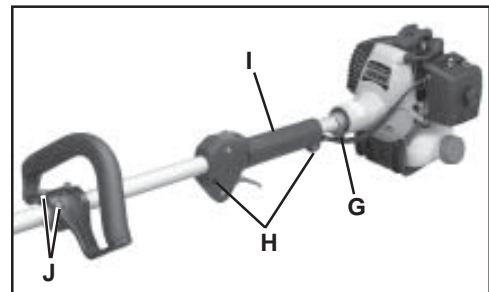
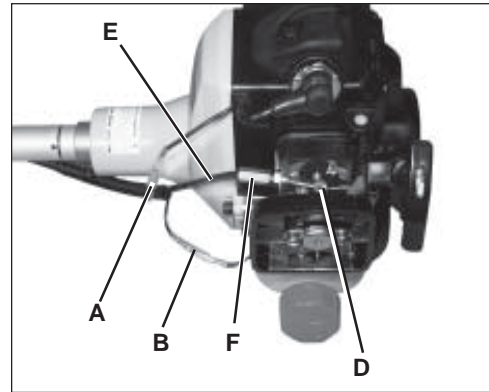

12. Route throttle linkage and ignition lead assembly around front of U-Handle bracket and clip to drive shaft as shown.

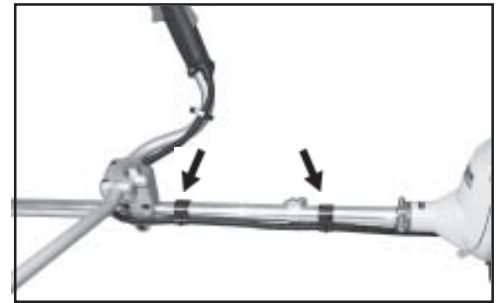

13. Place throttle linkage (E) through adjustment fixture (F) and install wire end into large carburetor throttle swivel hole (D). Check throttle for freedom of movement and that wide open throttle / low idle extremes are adjusted properly. The throttle linkage must be adjusted by moving the adjustment fixture (F). Consult with your Echo Dealer for correct adjustment procedure.

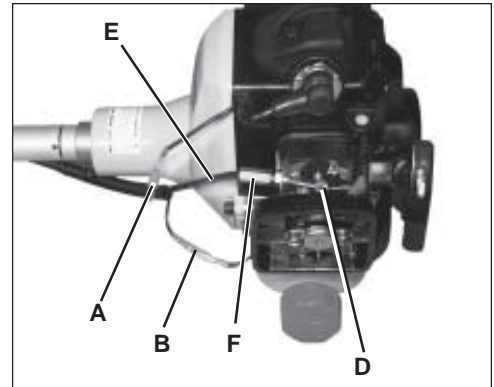

14. Connect ignition leads (A) and (B).

15. Remove left side clutch case bolt (P). Install metal bracket clamp (Q) with curved end up. Install throttle linkage into bracket clamp and pinch tight with pliers. Bend bracket up and flush against drive shaft.

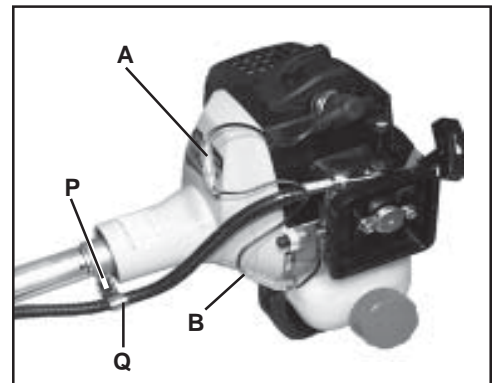

16. Install air filter and cover.

17. Balance unit.
  - a. Put on harness and attach unit to harness.
  - b. Slide harness clamp (R) up or down until unit balances with cutting attachment approximately 2 - 3" from ground.
  - c. Tighten harness clamp screw.



## MUFFLER BRACKET INSTALLATION

*Tools Required:* 4mm Hex Wrench

*Parts Required:* Muffler Bracket Kit P/N 10099057730

### IMPORTANT

Use of the Brush Cutter on U.S. Forest land and the states of California, Oregon and Washington requires installation of optional Muffler Bracket Kit P/N 10099057730.

1. Remove upper and lower bolts from right side of starter housing.
2. Position muffler bracket (A) over bolt holes so it extends over muffler cover.
3. Secure bracket using two (2) 4x16 socket head bolts (B) supplied with bracket kit.

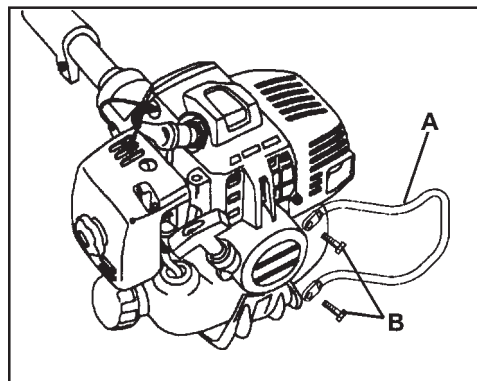

## PRE - OPERATION

### OPERATION WITH BLADES

#### *Preparing the Trimmer/Brush Cutter for Blade Use*

### WARNING DANGER

Blade use **DEMANDS** specific Brush Cutter configuration. Operation without specified shield and harness can result in serious personal injury.

**Plastic and Nylon Blades Require** "Blade Conversion Kit," P/N 99944200415 (TRI-CUT [A] and shoulder harness [B]).

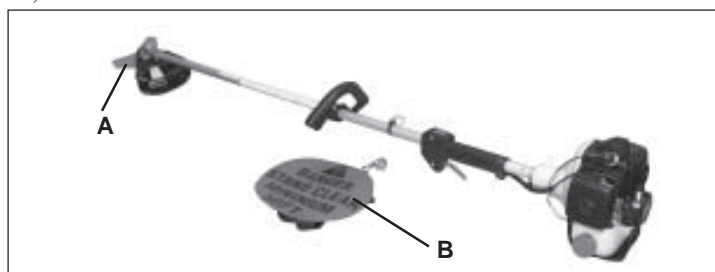

or U-Handle/Blade Conversion Kit P/N 99944200451



## Choosing the Correct Blade

### WARNING DANGER

The type of Blade used **MUST** be matched to the type and size of material cut. An improper or dull blade can cause serious personal injury. Blades **MUST** be sharp. Dull blades increase the chance of kick out and injury to yourself and bystanders.

**Plastic/Nylon Blades** may be used where ever the nylon line head is used. **DO NOT** use this blade for heavy weeds or brush! Blade Conversion Kit P/N 99944200415 is required for use with Nylon Blades.



**ss8 Tooth Weed/Grass Blade** (P/N 69600120331) is designed for grass, garden debris and thick weeds. **DO NOT** use this blade for brush or heavy woody growth, 3/4" in. (19 mm) diameter or larger. U-Handle / Blade Conversion Kit P/N 99944200521 is required for use with this blade.

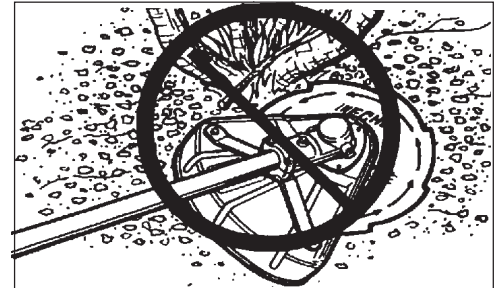

**Brush/Clearing Blade** (P/N 69500120330) is designed for cutting brush and woody growth up to 3" in. (76 mm) diameter. U-Handle / Blade Conversion Kit P/N 99944200521 is required for use with this blade.



**Use Shoulder/Waist Harness** (P/N 30100052131) Use of the Shoulder/Waist Harness is recommended for **ALL** Trimmer/Brush Cutter use, not just Blade operation. The Shoulder/Waist Harness when used in a trimming operation with nylon line head suspends the trimmer from the operator's shoulder and reduces operator fatigue.



During blade operation, the same fatigue reduction is achieved. Safety to the operator is also enhanced by reducing the possibility of blade contact with the operators hands and feet by restricting trimmer movement.

## FUEL

### *Fuel Requirements*

**Gasoline** - Use 89 Octane [ $\frac{R+M}{2}$ ] (mid grade or higher) gasoline or gasohol known to be good quality. Gasohol may contain up to 10% Ethyl (grain) alcohol or 15% MTBE (methyl tertiary-butyl ether). Gasohol containing methyl (wood) alcohol is **NOT** approved.

**Two Stroke Oil** - A two-stroke engine oil meeting ISO-L-EGD Standard (ISO/CD 13738), must be used. Echo brand Premium 50:1 oil meets this standard. Engine problems due to inadequate lubrication caused by failure to use an ISO-L-EGD approved oil, such as Echo Premium 50:1 Two-stroke Oil, will void the two-stroke engine warranty. (Emission related parts only are covered for two years, regardless of two-stroke oil used, per the statement listed in the California Emission Defect Warranty Explanation.)

**Mixing** - Follow directions on the oil container.

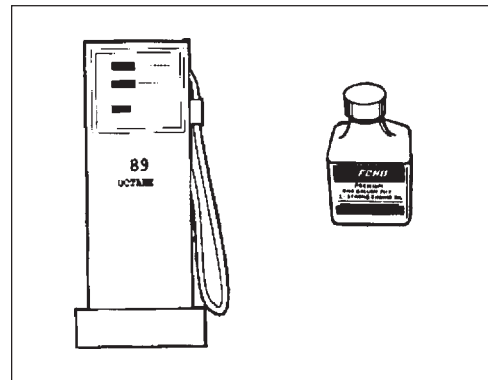

### *Handling Fuel*

#### **WARNING** **DANGER**

Fuel is **VERY** flammable. Use extreme care when mixing, storing or handling, otherwise serious personal injury may result.

- Use an approved fuel container.
- **DO NOT** smoke near fuel.
- **DO NOT** allow flames or sparks near fuel.
- Fuel tanks/cans may be under pressure. Always loosen fuel caps slowly allowing pressure to equalize.
- **NEVER** refuel a unit when the engine is **HOT!**
- **NEVER** refuel a unit with the engine running.
- **DO NOT** fill fuel tanks indoors. **ALWAYS** fill fuel tanks outdoors over bare ground.
- Securely tighten fuel cap after refueling.
- Inspect for fuel leakage. If fuel leakage is found, do not start or operate unit until leakage is repaired.

#### **IMPORTANT**

Spilled fuel is a leading cause of hydrocarbon emissions. Some states may require the use of automatic fuel shut-off containers to reduce fuel spillage. Contact your ECHO dealer for ordering information.





## After Refueling;

- Wipe any spilled fuel from the unit.
- Move at least 3 M (10 ft.) from refueling location before starting.

## After Use;

- DO NOT store a unit with fuel in its tank. Leaks can occur. Return unused fuel to an approved fuel storage container.

## Storage -

Fuel storage laws vary by locality. Contact your local government for the laws affecting your area. As a precaution, store fuel in an approved, air tight container. Store in a well ventilated, unoccupied building, away from sparks and flames. Do not store fuel longer than 30 days.

### IMPORTANT

Stored fuel ages. Do not mix more fuel than you expect to use in thirty (30) days, ninety (90) days when a fuel stabilizer is added.

### IMPORTANT

Stored two-stroke fuel may separate. ALWAYS shake fuel container thoroughly before each use.

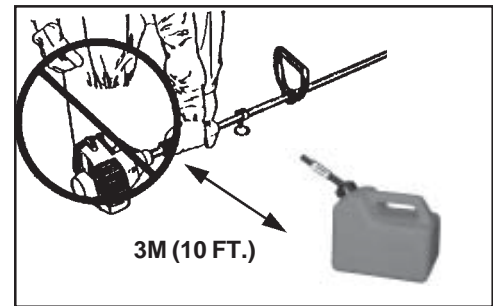

S	M	T	W	T	F	S
1	2	3	4	5	6	7
8	9	10	11	12	13	14
15	16	17	18	19	20	21
22	23	24	25	26	27	28
29	30	31				

## EQUIPMENT CHECK

Before operation a complete check of the unit must be performed;

- Check unit for loose/missing nuts, bolts and screws. Tighten and/or replace as needed.
- Inspect fuel lines, tank and area around carburetor for fuel leaks. DO NOT operate unit if leaks are found.
- Inspect shield for damage and ensure that the cut-off knife is securely in place. Replace if either is damaged or missing.
- Check that the cutting attachment is firmly attached and in safe operating condition.
- Check that front (loop) handle and optional shoulder/waist harness are adjusted for safe, comfortable operation. See Assembly Section for proper adjustment.



## DETERMINE OPERATION AREA

### WARNING DANGER

Inspect starting area for hazards such as rocks, glass, debris etc. which could be contacted by the cutting attachment when starting. Keep helpers and bystanders at least 15 M (50 ft.) from starting area, otherwise serious personal injury may result.

- Before starting the unit, equip yourself and any other person working within the 15M (50 ft.) Safety Zone with the required Protective Equipment and clothing.
- Spectators and fellow workers must be warned, and children and animals prevented from coming nearer than 15M (50 ft.) while the trimmer is in use.

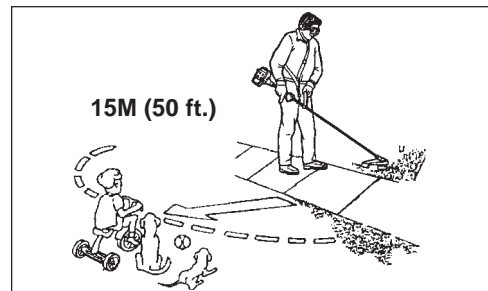
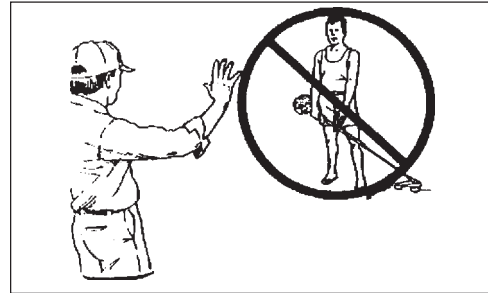

## OPERATION

- Provide all operators of this equipment with the Operator's Manual, and instructions for safe operation.
- Refer to the Safety Manual provided with the unit for proper trimming and brush cutting techniques.
- During operation, the complete unit, especially the drive shaft housing and the bearing housing may become very hot, too hot to touch. Avoid contact during and immediately after operation.

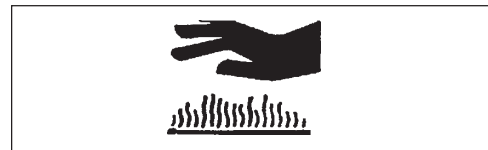
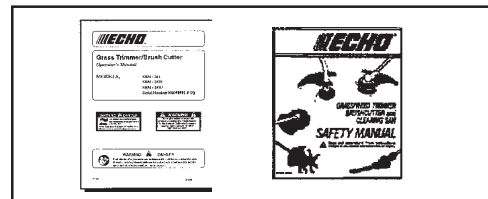

## STARTING COLD ENGINE

### WARNING DANGER

The cutting attachment should not rotate at idle. If attachment rotates, readjust carburetor according to "Carburetor Adjustment" instructions in this manual or see your ECHO Dealer, otherwise serious personal injury may result.

1. *Stop Switch* - Start/Run.  
Move stop switch button (A) forward away from the STOP position.

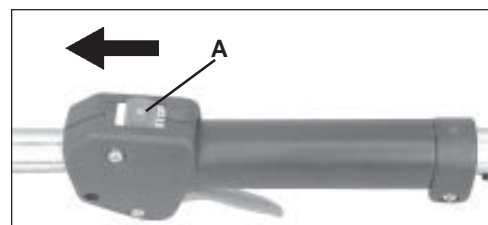



2. *Close Choke - Cold Start.*  
Move choke lever (B) to Cold Start Position.

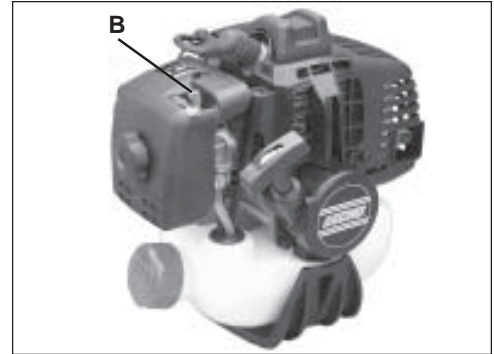

3. *Primer - Pump Bulb.*  
Pump primer bulb (C) 10 times until fuel is visible in the "Clear" fuel return line (D).

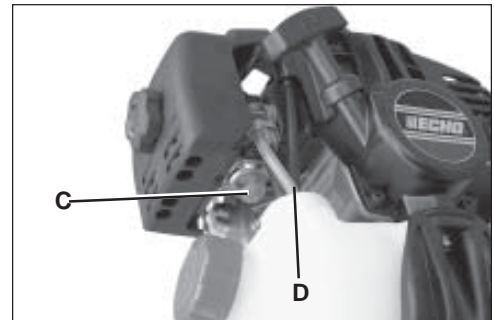

4. *Start - Pull Rope.*  
Lay the trimmer on a flat clear area and pull the recoil starter handle (E) until engine fires.
5. *Open Choke - Run.*  
Move the choke lever to the OPEN - RUN position. Restart engine if necessary and allow to warm up running at idle for several minutes.

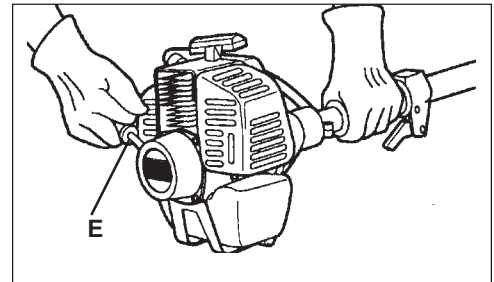

## STARTING WARM ENGINE

The starting procedure is the same as Cold Start except DO NOT close the choke.

### NOTE

If engine does not start after 5 pulls, use Cold Start Procedure.

### WARNING DANGER

When engine starts, the cutting attachment may rotate even with the throttle trigger in idle (released) position.

1. *Stop Switch - Start/Run.* Move stop switch button (A) away from the STOP position.

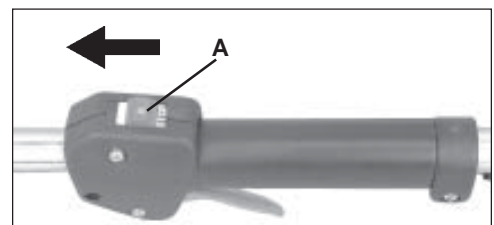

2. *Primer - Pump Bulb.* Pump primer bulb (C) until fuel is visible in the "Clear" fuel return line (D).
3. *Start - Pull Rope.* Lay the trimmer on a flat clear area and pull the recoil starter handle (E) until the engine fires.

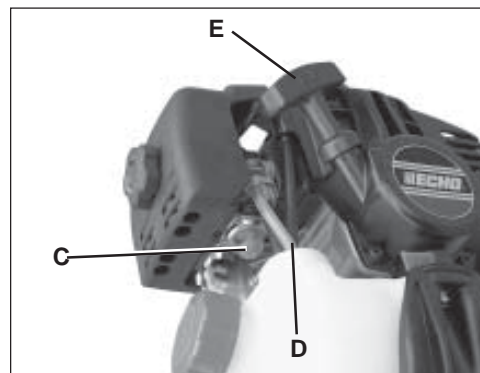

## STOPPING ENGINE

1. *Release Throttle.* Allow engine to idle for a minute.
2. *Stop Switch - Stop.* Move stop switch button (A) backward to STOP position.

### WARNING DANGER

If engine does not stop when stop switch is moved to STOP position, close choke - COLD START position - to stall engine. Have your ECHO dealer repair stop switch before using trimmer again.

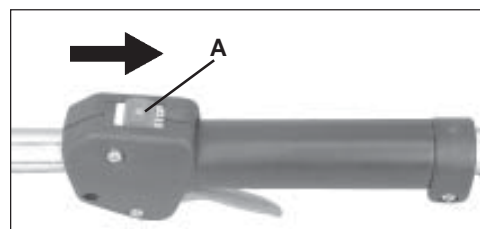

## MAINTENANCE

Your ECHO trimmer is designed to provide many hours of trouble free service. Regular scheduled maintenance will help your trimmer achieve that goal. If you are unsure or are not equipped with the necessary tools, you may want to take your unit to an ECHO Service Dealer for maintenance. To help you decide whether you want to DO-IT-YOURSELF or have the ECHO Dealer do it, each maintenance task has been graded. If the task is not listed, see your ECHO Dealer for repairs.

## SKILL LEVELS

- Level 1**= Easy to do. Most required tools come with unit.
- Level 2**= Moderate difficulty. Some specialized tools may be required.
- Level 3**= Experience required. Specialized tools are required. ECHO recommends that the unit be returned to your ECHO dealer for servicing.

ECHO offers **REPOWER™** Maintenance Kits and Parts to make your maintenance job easier. Below each task heading are listed the various part numbers required for that task. See your ECHO dealer for these parts.

## INTERVALOS DE MANTENIMIENTO

Componente/ Sistema	Procedimiento de Mantenimiento	Necesarias nivel de habilidad	Dia iamente o Antes de usar	Al cargar combustible	3 meses o 90 horas	6 meses o 270 horas	Anualmente
<b>Procedimientos De Mantenimiento Recomendados Del Distribuidor Echo</b>							
Orificio de escape del cilindro	Inspeccionar/Limpiar/ Descarbonizar	<b>3</b>			<b>I / L</b>		
<b>Procedimientos De Mantenimiento De Do-It-Yourself</b>							
Filtro de aire	Inspeccionar/ Limpiar/ Reemplazar	<b>1</b>	<b>I / L</b>		<b>R*</b>		
Estrangulador	Inspeccionar/Limpiar	<b>2</b>	<b>I / L</b>				
Filtro de combustible	Inspeccionar/Reemplazar	<b>1</b>			<b>I</b>		<b>R*</b>
Sistema de combustible, Fugas	Inspeccionar/Reemplazar	<b>1</b>	<b>I *</b>	<b>I</b>			
Sistema de enfriamiento	Inspeccionar/Limpiar	<b>2</b>	<b>I / L</b>				
Apagachispas del silenciador	Inspeccionar/Reemplazar	<b>2</b>			<b>I / R *</b>		
Eje de impulsión (modelos de cable flexible)	Engrasar	<b>2</b>			<b>I (1)</b>		
Caja de engranajes	Engrasar	<b>2</b>			<b>I (2)</b>		
Cuerda del motor de arranque	Inspeccionar/Limpiar	<b>1</b>	<b>I / L</b>				<b>I / R*</b>
Bujía	Inspeccionar/Limpiar	<b>2</b>			<b>I / L</b>	<b>R*</b>	
Tornillos/Tuercas/ Pernos	Inspeccionar/Apretar/ Reemplazar	<b>1</b>	<b>I / R*</b>				
<p><b>CÓDIGOS DE LETRAS DEL PROCEDIMIENTO DE M MANTENIMIENTO:</b> I INSPECCIONAR, R = REEMPLAZAR, L = LIMPIAR</p> <p><b>NOTA IMPORTANTE</b> - Los intervalos indicados son máximos. El uso real y su experiencia determinarán la frecuencia del mantenimiento requerido.</p> <p><b>NOTAS DE PROCEDIMIENTOS DE MANTENIMIENTO:</b></p> <p>(1) Aplique el LUBRICANTE™ de ECHO® cada 25 horas de uso.</p> <p>(2) Aplique el LUBRICANTE™ de ECHO® cada 50 horas de uso.</p> <p>* Todas las recomendaciones de reemplazo se basan en encontrar piezas dañadas o desgastadas durante la inspeccion.</p>							

## AIR FILTER

### Level 1.

*Tools required:* 25 or 50 mm (1 or 2 in.) medium bristle cleaning brush.

*Parts required:* 90030 REPOWER™ AIR & FUEL FILTER KIT.

1. Close choke (Cold Start Position). This prevents dirt from entering the carburetor throat when the air filter is removed. Brush accumulated dirt from the air cleaner area.
2. Remove the air cleaner cover. Clean and inspect the element for damage. If element is fuel soaked and very dirty, replace.
3. If element can be cleaned and reused, be certain it:
  - still fits the cavity in the air cleaner cover.
  - is installed with the original side out.

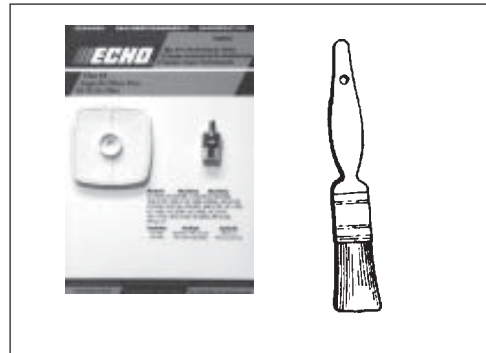

## FUEL FILTER

### Level 1.

*Tools required:* Fuel line hook, 203-254 mm (8-10 in.) length of wire with one end bent into a hook. Clean rag, funnel, and an approved fuel container.

*Parts required:* 90030 REPOWER™ AIR & FUEL FILTER KIT.

### WARNING DANGER

Fuel is **VERY** flammable. Use extreme care when mixing, storing or handling.

1. Use a clean rag to remove loose dirt from around fuel cap and empty fuel tank.
2. Use the “fuel line hook” to pull the fuel line and filter from the tank.
3. Remove the filter from the line and install the new filter.

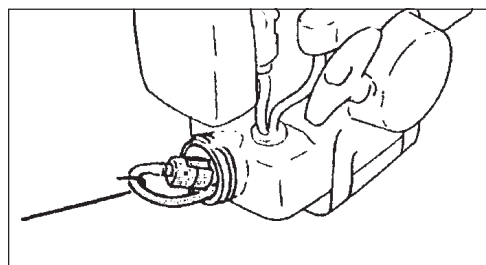

## SPARK PLUG

### Level2.

*Tools Required:* T-Wrench (combination socket wrench & screw driver supplied with unit) Feeler gauge, preferably a wire gauge. Soft Metal Brush.

*Parts Required:* Spark Plug, NGK BPM-7Y P/N99944500071

1. Remove spark plug and check for fouling, worn and rounded center electrode.
2. Clean the plug or replace with a new one. DO NOT sand blast to clean. Remaining sand will damage engine.
3. Adjust spark plug gap by bending outer electrode.
4. Tighten spark plug to 145-155 kg/cm (125-135 in. lb.).

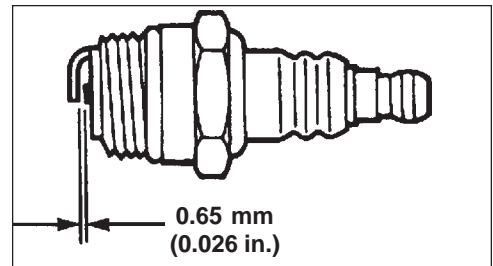
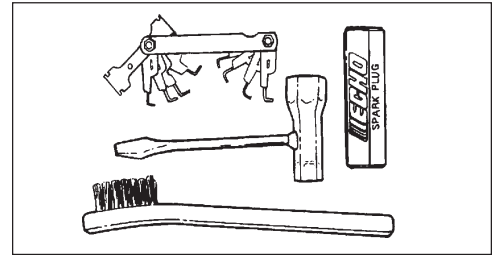

## COOLING SYSTEMS CLEANING

### Level2.

*Tools required:* Cross Head Screwdriver, 4 mm Hex Wrench, 25 or 50 mm (1 or 2 in.) medium bristle cleaning brush.

*Parts Required:* None if you are careful.

### IMPORTANT

To maintain proper engine operating temperatures, cooling air must pass freely through the cylinder fin area. This flow of air carries combustion heat away from the engine.

Overheating and engine seizure can occur when:

- Air intakes are blocked, preventing cooling air from reaching the cylinder.
- Dust and grass build up on the outside of the cylinder. This build up insulates the engine and prevents the heat from leaving.

Removal of cooling passage blockages or cleaning of cooling fins is considered "Normal Maintenance". Any failure attributed to lack of maintenance is not warranted.

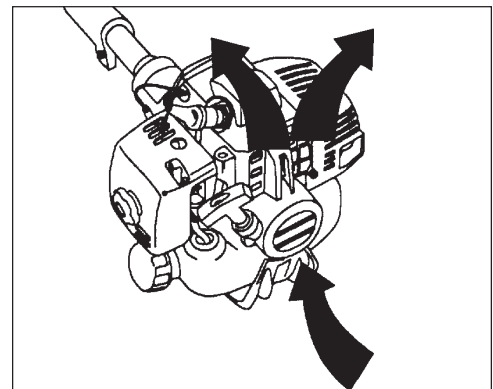
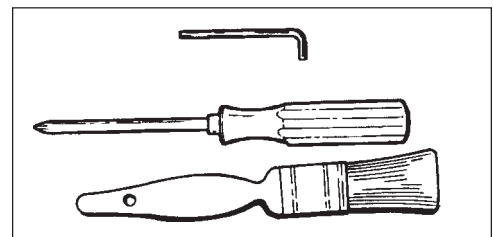

1. Remove air filter cover (A).
2. Remove spark plug lead.
3. Remove two (2) muffler cover screws and muffler cover (B).
4. Remove screw and arm rest (C).
5. Remove two (2) front cylinder cover screws and cylinder cover (D).

**IMPORTANT**

DO NOT use a metal scraper to remove dirt from the cylinder fins.

6. Use brush to remove dirt from the cylinder fins.
7. Remove grass and leaves from the grid between the recoil starter and fuel tank.

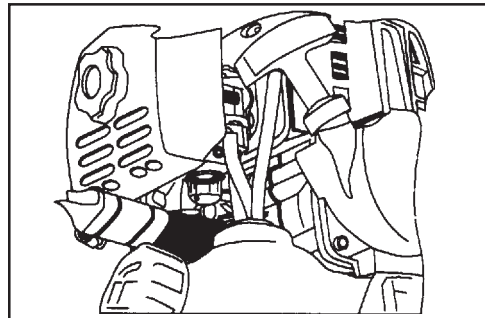
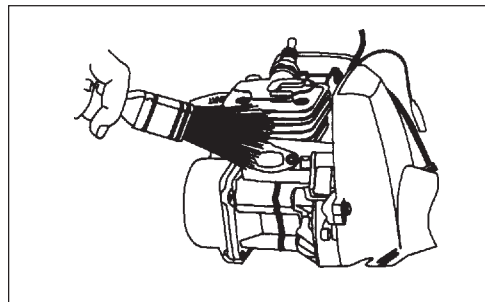
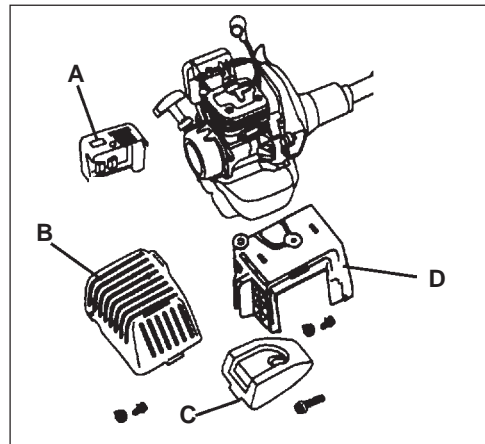

## EXHAUST SYSTEM

### Spark Arrester Screen

#### Level 2.

*Tools Required:* Cross Head Screwdriver, Wooden carbon scraper, 3 and 4 mm Hex Wrench

*Parts Required:* Spark Arrestor Screen P/N 14586240630,  
Gasket P/N 14586642031.

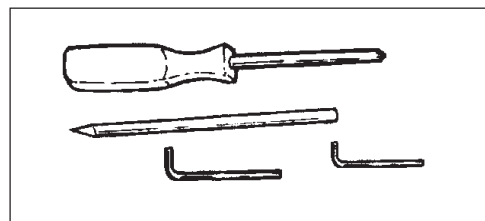

1. Remove engine cover (A). See "Cleaning Cooling System" pages 29 & 30 for step by step instructions.
2. Place piston at Top Dead Center (TDC) to prevent carbon/dirt from entering cylinder.
3. Remove spark arrestor screen cover (B), screen holder (C), gasket (D) and screen (E) from muffler body.
4. Clean carbon deposits from screen and muffler components.
5. Replace screen if it is cracked, plugged or has holes burned through.
6. Assemble components in reverse order.

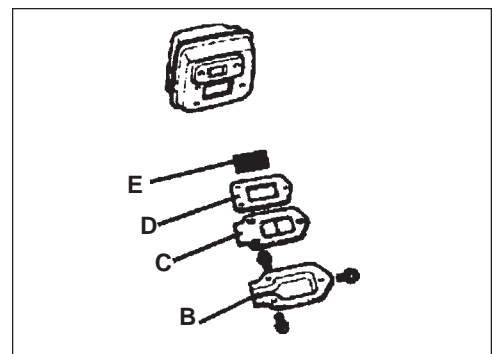
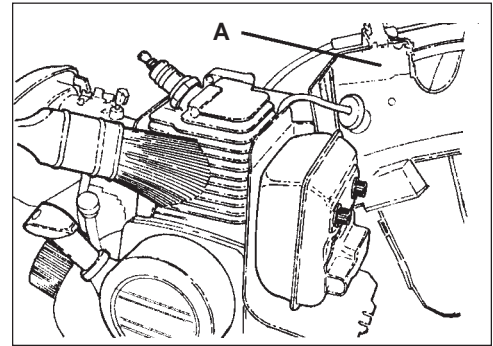

## CARBURETOR ADJUSTMENT

### Level 2.

*Tools required:* Screwdriver, Tachometer (ECHO P/N 99051130017).

*Parts required:* None.

#### NOTE

Every unit is run at the factory and the carburetor is set in compliance with California Emission Regulations. This carburetor does not have acceleration and high speed adjustment needles. Do not attempt to use carburetor adjustment procedures provided in the Warranty/Emissions Booklet.

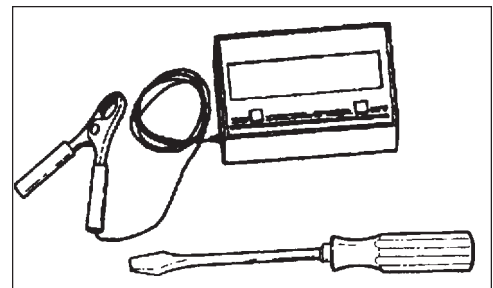

1. Check idle speed and reset if necessary. If a tachometer is available, idle speed screw (A) should be set to the specifications found on page 13 "Specifications" of this manual. Turn idle screw (A) clockwise to increase idle speed; counter clockwise to decrease idle speed.

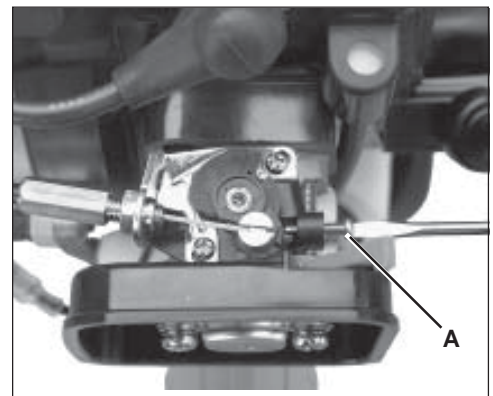

### WARNING DANGER

When carburetor adjustment is completed, the cutting attachment should not turn at idle, otherwise serious personal injury may result.

## LUBRICATION

### Level 1.

*Tools Required:* 8 mm Open End Wrench, Screwdriver, Clean Rag.

*Parts Required:* Lithium Base Grease.

### Gear Housing

1. Clean all loose debris from gear box.
2. Remove plug (A) and check level of grease.
3. Add grease if necessary, DO NOT over fill.

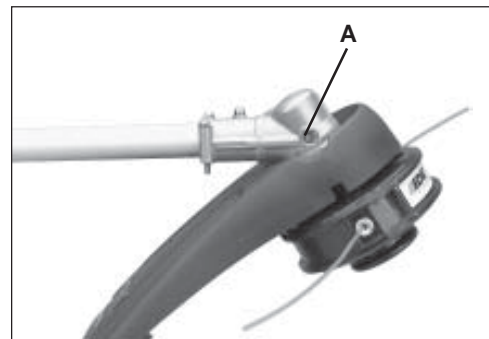
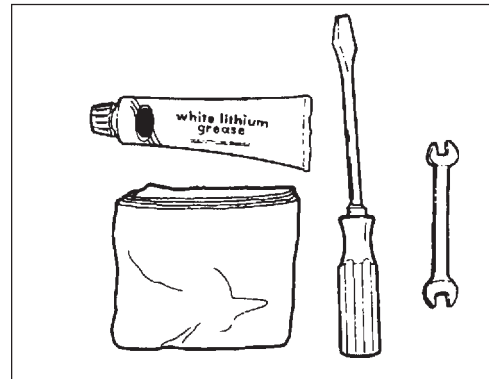

## NYLON LINE REPLACEMENT

### Level 1.

*Tools Required:* Head locking tool (if head is to be removed)

*Parts Required:* ECHO 0.095" Nylon Trimmer Line 12m (40 feet) long.

1. Hold drum (A) and turn spool (B) CW (clockwise) until it stops. Pull spool from drum. DO NOT push in on spool when turning.
2. Use one piece of new nylon line (C) 12m (40 feet) long and thread through the molded loop (D) on the spool. Pull line tight and adjust so one end is 15 cm (6 in.) longer than the other.

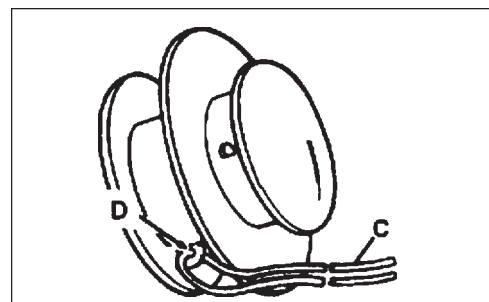
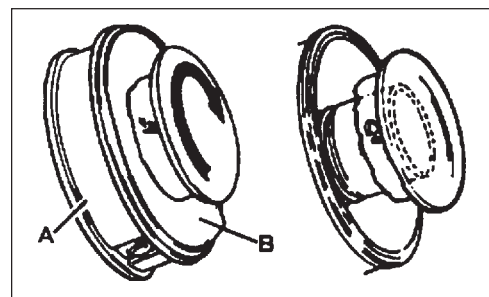
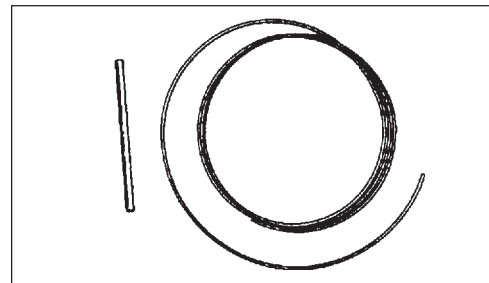



3. Hold the spool, opening toward you. Place index finger between the two strands and wind line, tightly and evenly, in direction of arrow marked "CC".
4. Stop when approximately 15-20 cm (6 - 8 in.) line (C) remains and place ends of line in notches (E) in spool (B).

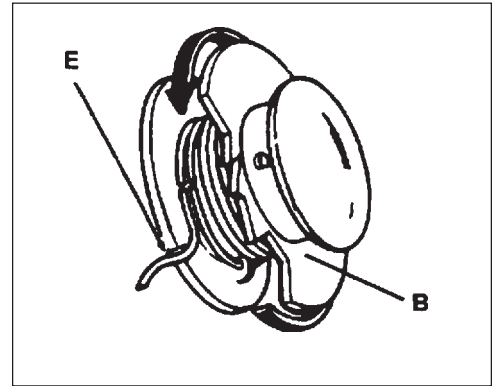

5. Feed ends of line through housing eyelets (F) and place spool (B) over drive (G). Align pegs (H) on drive with notches in spool and push spool into drum.
6. Pull on both lines until they come free from notches (E) in spool.

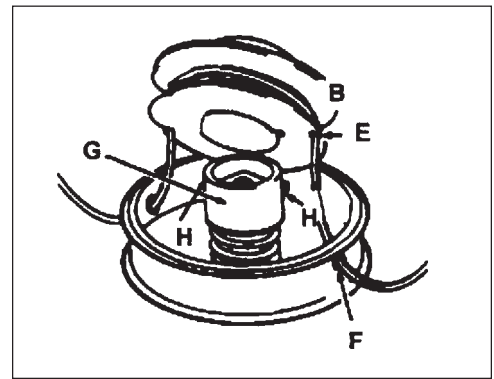

7. Hold drum (A) firmly and turn spool (B) CCW (counterclockwise) until it stops. DO NOT push in on spool when turning.
8. Pull both lines out and trim to cut-off knife length.

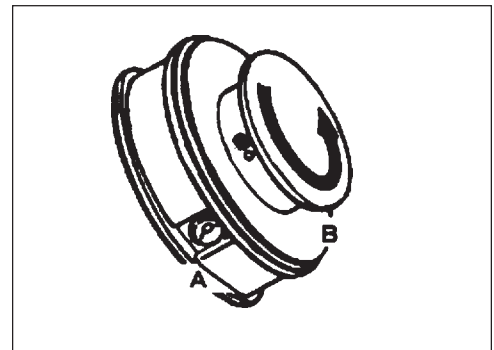

## SHARPENING METAL BLADES

Three styles of metal blades are approved for use on the ECHO Brush Cutter. The 8-tooth blade can be sharpened during normal maintenance. The clearing blade and 80 tooth blade require professional service.

Before sharpening, CLOSELY inspect blade for cracks (look at the bottom of each tooth and the center mounting hole closely), missing teeth and bending. If ANY of these problems are discovered, replace the blade.

When sharpening a blade, always remove the same amount of materials from each tooth to maintain balance. A blade that is not balanced will cause unsafe handling due to vibration and can result in blade failure.

### ***8-tooth Blade***

*Tool required:* Flat file (preferred). Electric grinder if special care is used. Round (rat tail) file for gullet (radius).

1. File each tooth at a 30 degree angle a specific number of times, eg. 4 strokes per tooth. Work your way around the blade until all teeth are sharp.
2. DO NOT file the 'gullet' (radius) of the tooth with the flat file. The radius must remain. A sharp corner will lead to a crack and blade failure.

#### **IMPORTANT**

If an electric grinder is used, use care not to overheat teeth, do not allow tips/tooth to glow red or turn blue. DO NOT place blade in cooling water. This will change the temper of the blade and could result in blade failure.

3. After sharpening teeth, check each tooth radius for evidence of a square (sharp) corner. Use the round (rat tail) file to renew the radius.

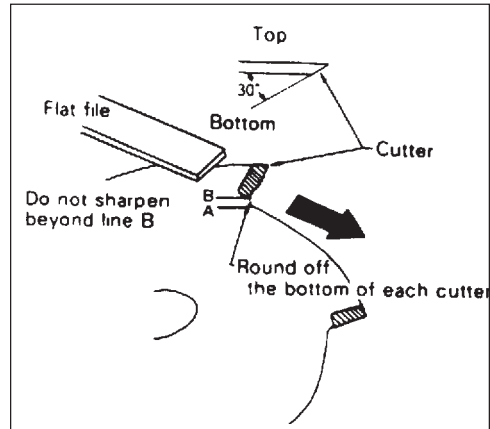
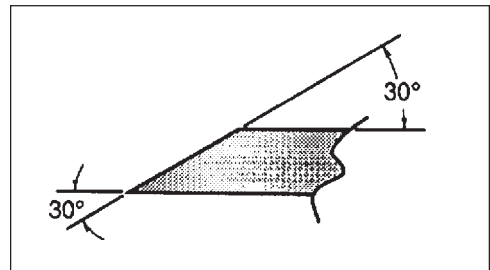
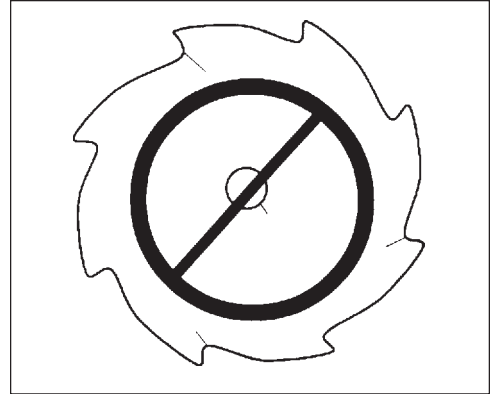

## TROUBLESHOOTING

Problem				
Engine -- starts hard				
Engine -- does not start			Cause	Remedy
Engine Cranks	Fuel at carburetor	No fuel at carburetor	Fuel strainer clogged Fuel line clogged Carburetor	Clean Clean See your ECHO dealer
	Fuel at cylinder	No fuel at cylinder	Carburetor	See your ECHO dealer
		Muffler wet with fuel	Fuel Mixture is too rich	Open choke Clean/replace air filter Adjust carburetor See your ECHO dealer
	Spark at end of plug wire	No spark at end of plug wire	Stop switch off Electrical problem	Turn switch on See your ECHO dealer
	Spark at plug	No spark at plug	Spark gap incorrect Covered with carbon Fouled with fuel Spark plug defective	Adjust 0.65mm (0.026in.) Clean or replace Clean or replace Replace plug
Engine does not crank			Internal engine problem	See your ECHO dealer
Engine runs	Dies or accelerates poorly		Air filter dirty Fuel filter dirty Fuel vent plugged Spark plug Carburetor Cooling system plugged Spark arrestor screen plugged	Clean or replace Replace Replace Clean and adjust/replace Adjust Clean Clean

**WARNING  DANGER**

Fuel vapors are **extremely** flammable and may cause fire and/or explosion. **Never** test for ignition spark near an open spark plug opening, otherwise serious personal injury may result.

## STORAGE

### *Long Term Storage (over 30 days)*

#### WARNING DANGER

During operation the muffler or catalytic muffler and surrounding cover become hot. Always keep exhaust area clear of flammable debris during transportation or when storing, otherwise serious property damage or personal injury may result.

Do not store your unit for a prolonged period of time (30 days or longer) without performing protective storage maintenance which includes the following:

1. Store unit in a dry, dust free place, out of the reach of children.

#### WARNING DANGER

Do not store in enclosure where fuel fumes may accumulate or reach an open flame or spark.

2. Place the stop switch (A) in the "OFF" position.
3. Remove accumulation of grease, oil, dirt and debris from exterior of unit.
4. Perform all periodic lubrication and services that are required.
5. Tighten all the screws and nuts.
6. **Drain** the fuel tank **completely** and pull the recoil starter handle several times to remove fuel from the carburetor.
7. Remove the spark plug and pour 7 cc (1/4 oz. 1/2 tablespoon) of fresh, clean, two-stroke engine oil into the cylinder through the spark plug hole.
  - A. Place a clean cloth over the spark plug hole.
  - B. Pull the recoil starter handle 2-3 times to distribute the oil inside the engine.
  - C. Observe the piston location through the spark plug hole. Pull the recoil starter handle slowly until the piston reaches the top of its travel and leave it there.
8. Install the spark plug (do not connect ignition cable).

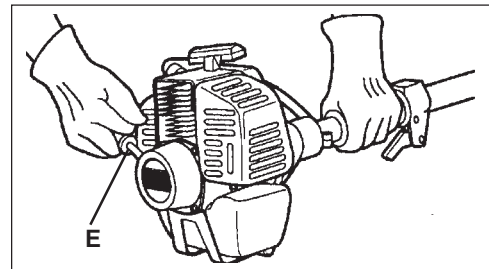
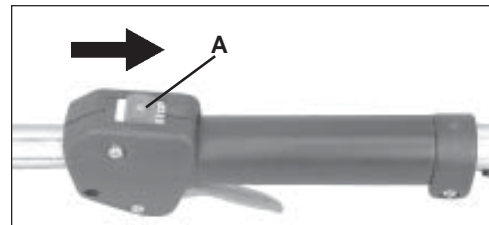

**NOTES**

**NOTES**

**NOTES**

# SERVICING INFORMATION

## PARTS

Genuine ECHO Parts and ECHO REPOWER™ Parts and Assemblies for your ECHO products are available only from an Authorized ECHO Dealer. When you do need to buy parts **always** have the Model Number, Type Number and Serial Number of the unit with you. You can find all three numbers on the engine housing. For future reference, write them in the space provided below.

Model No. \_\_\_\_\_ Type No. \_\_\_\_\_ SN. \_\_\_\_\_

## SERVICE

Service of this product during the warranty period must be performed by an Authorized ECHO Service Dealer. For the name and address of the Authorized ECHO Service Dealer nearest you, ask your retailer or call: 1-800-432-ECHO. When presenting your unit for Warranty service/repairs, proof of purchase is required.

## ECHO CONSUMER PRODUCT SUPPORT

If you require assistance or have questions concerning the application, operation or maintenance of this product you may call the ECHO Consumer Product Support Department at 1-800-673-1558 from 8:00 am to 5:00 pm (Central Standard Time) Monday through Friday. Before calling, please know the model and serial number of your unit to help your Consumer Product Support Representative.

## WARRANTY CARD

This card is our means of registering all original owners of ECHO equipment. The card plus proof of purchase provides you the assurance that authorized warranty work will be done. It also provides a direct link between you and ECHO if we find it necessary to contact you.

## ADDITIONAL OR REPLACEMENT MANUALS

**Safety Manuals** are available, free of charge, from your ECHO dealer or by contacting Echo Incorporated, 400 Oakwood Road, Lake Zurich, IL 60047

**Operator's and Parts Manuals** are available for purchase from your ECHO dealer or directly from ECHO. [See ordering instructions at the end of this manual.]

**Safety Video** is available from your dealer. A \$5.00 shipping charge will be required.

## ORDERING INSTRUCTIONS

To obtain a Parts Catalog or Operator's Manual send a check or money order for \$2.00 per Parts Catalog or \$1.50 per Operator's Manual made payable to ECHO, INCORPORATED. State on a sheet of paper model number and serial number of the ECHO unit you have, part number of the manual (if known), your name and address and mail to address above.

### Available Parts Lists

SRM-2601/2610 S/N 001001 & UP

PART NUMBER 99922202915

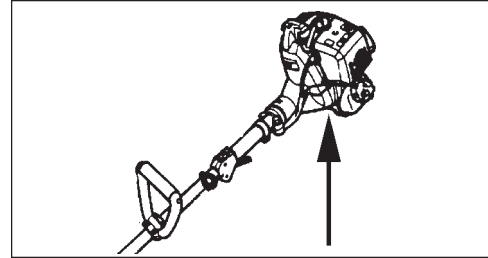

## DEALER?

Call

**1-800-432-ECHO**

**1-800-432-3246**

## CONSUMER PRODUCT SUPPORT

**1-800-673-1558**

**8 - 5 Mon - Fri C.S.T.**

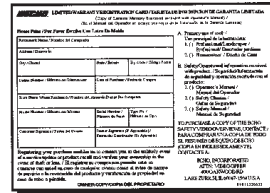

ECHO Incorporated  
400 Oakwood Road  
Lake Zurich, IL 60047  
Technical Publications Orders

**ECHO**  
ECHO, INCORPORATED  
400 OAKWOOD ROAD  
LAKE ZURICH, IL 60047